

Compaction, the art of sticking together

An Introduction to

High Efficient Particle Agglomeration methods using Pressing Forces

- in a dry way with or without additional binders –

October 25, 2016

Menno Logmans - Hosokawa Micron Group



Why (dry) Agglomeration

1. Prevent segregation of mixtures
2. Increase bulk density (savings on storage / shipping)
3. De-dusting (safety, handling, ...)
4. Create a narrow particle size distribution
5. Improve handling & metering properties
6. Improve efficiency/capacity of tablet presses, sachet filling, capsule filling
7. Influence (+ or -) dissolving properties, surface reactivity
8. Allow proper gas permeability (furnace / calcining processes)
9. Improve granule (deformation) stability, reduce attrition

→ Usage of binders required?!



Alpine press-agglomeration methods

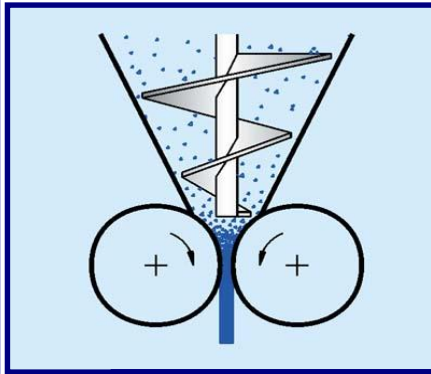

Compactor

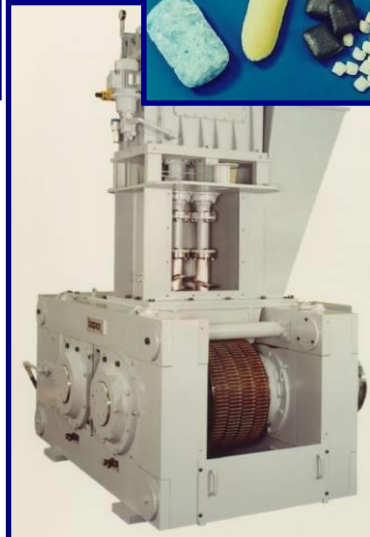
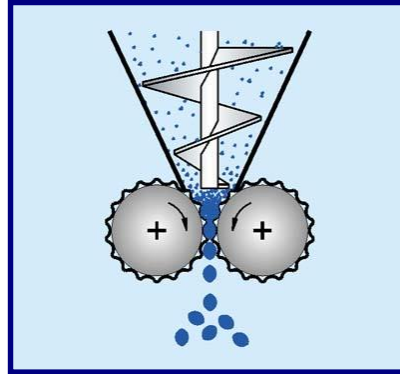

Briquetting

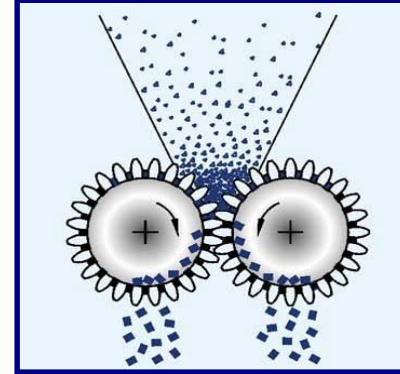

Gear Pelletizer

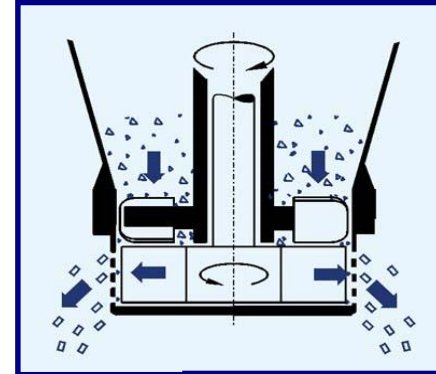

Bextruder



Part 1

Briquetting and Dry Granulation

(briquetting + roll compaction)

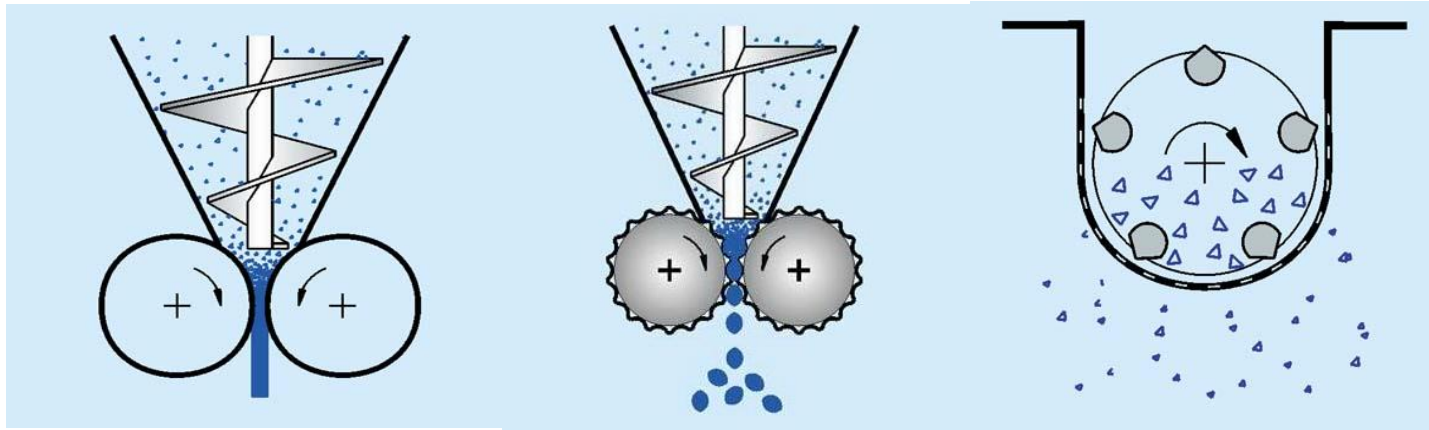

General Basics 1

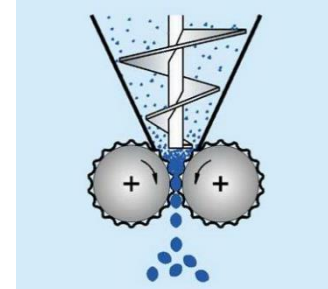

With material bridges

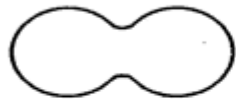

**Chemical reactions,
sintering, melting**



Adsorption layers



**Liquid bridges
Binder bridges**



Form fit binding

Without material bridges

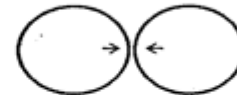

**Molecular forces
Van-der-Waals-Forces**

10^{-10} m
 10^{-4} μ m

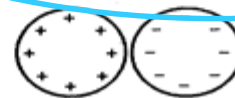

Electrostatic forces



Magnetic forces

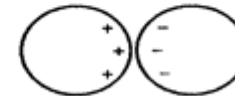

Valence forces



General Basics 2

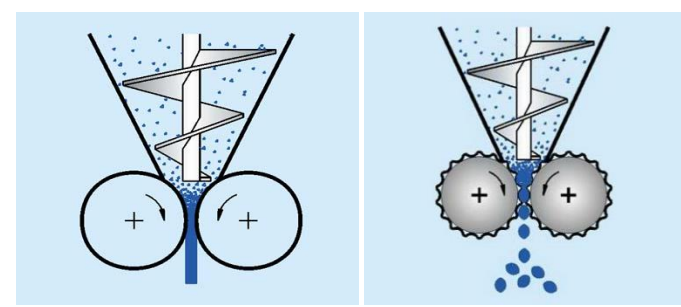

1. Compaction is no more than removing gasses from products. Densification can go up to e.g. 95% of the specific density. E.g. 100 → 1000 g/ltr
2. External high forces on the particles by pre-densifier screw and rollers. These lead to the required “Van der Waals” forces.
3. No liquid binders/solutions are necessary – therefore no subsequent drying required → Minimal risk of thermal damage of the products.
4. The particle size of the materials to be processed is not very important. Pre-grinding is usually not required.
5. Too high press forces (“overpressing”) can destroy already created agglomerates and add significant heat → reduced process efficiency



Forces in the Working Gap

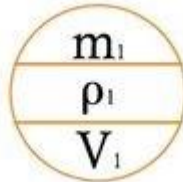

Vacumizing?

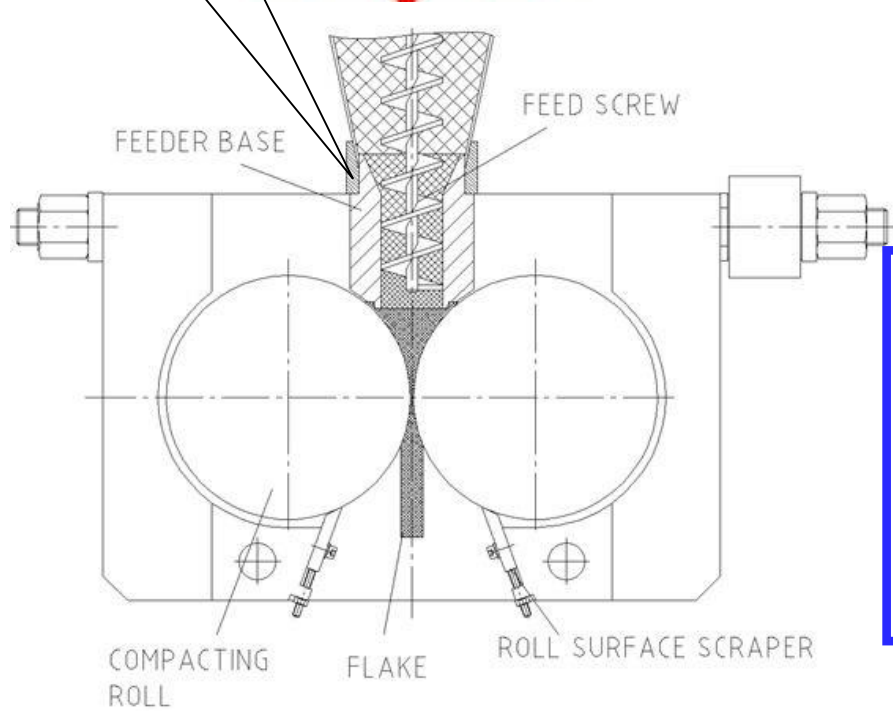

Pressing force $\leq 600 \text{ mt}$
 Specific force typically 1 to 20 N/mm^2
 Capacity range ~ 20 to 120.000 kg/h

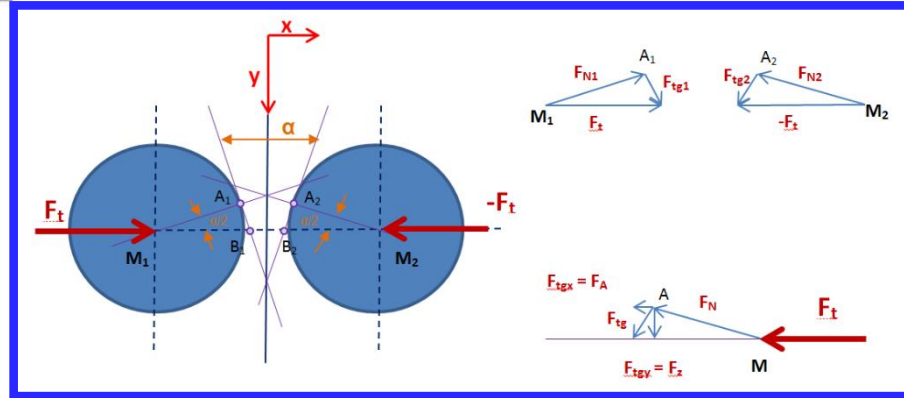

source: Aufbereitungstechnik 44 (2003) Nr. 8



HOSOKAWA ALPINE Compaction
 A Division of HOSOKAWA ALPINE Aktiengesellschaft

Compactor set-up

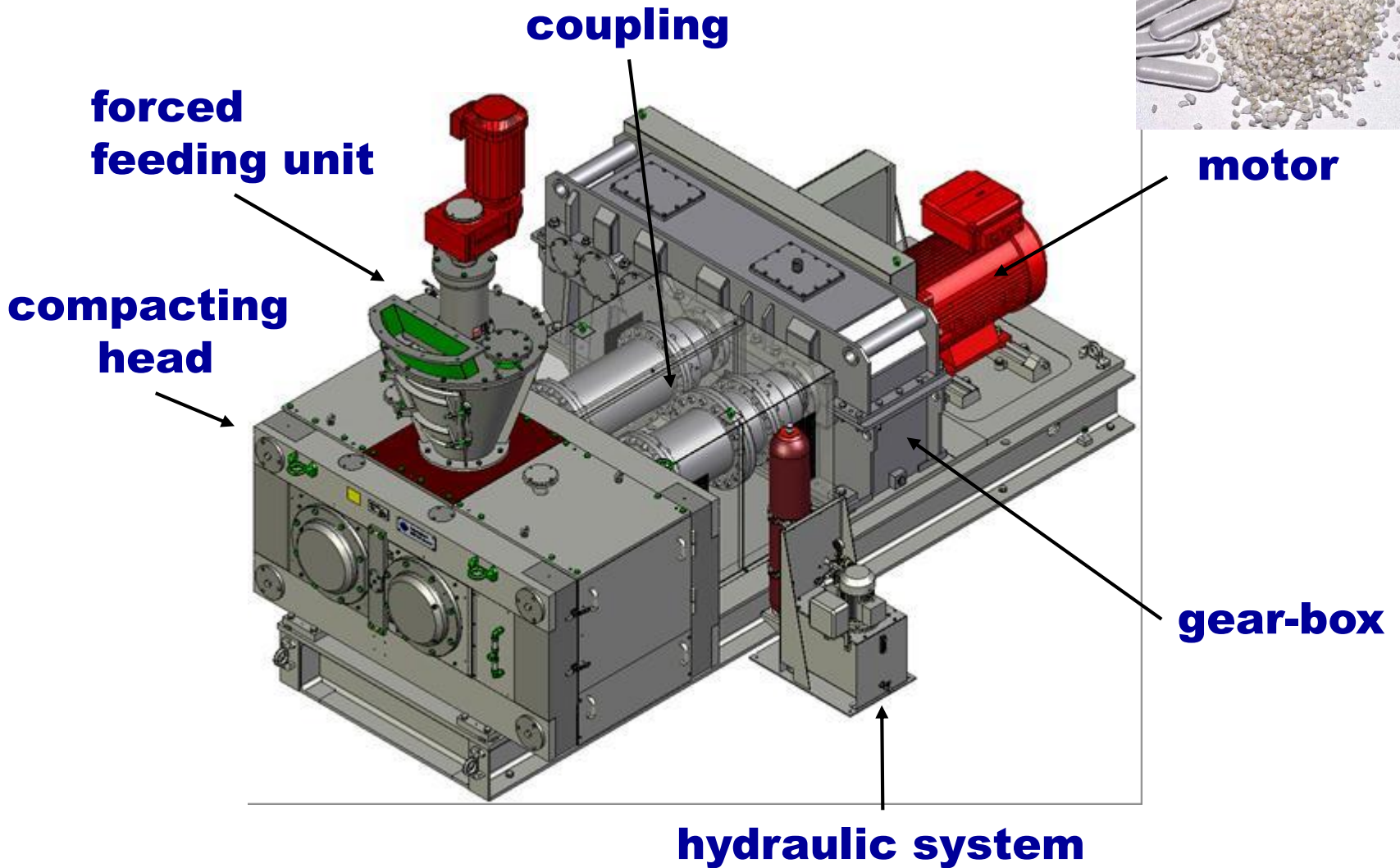

Briquetting plant

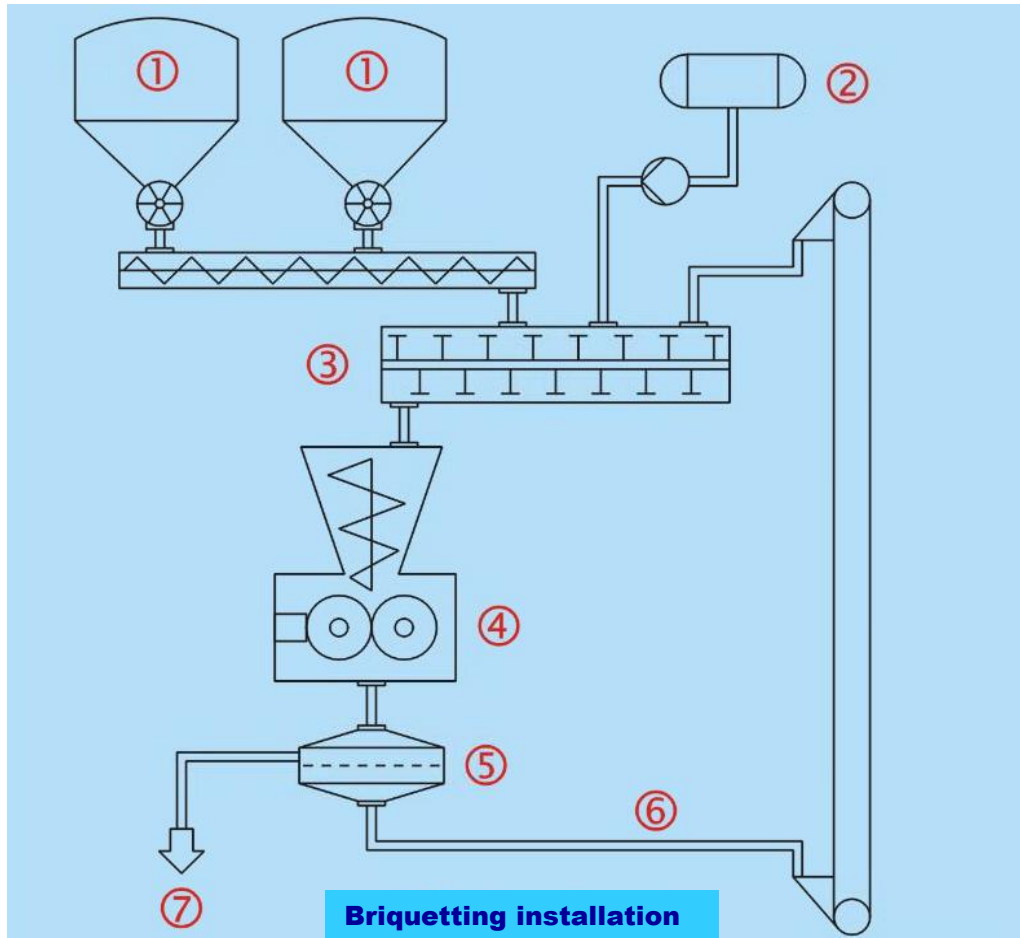

1. Silos, raw materials dosing
2. (Liquid addition)
3. Mixer
4. Briquetting press
5. (Safety) Screen
6. Fines recycling
7. Final product - briquettes

Roll compaction + granulation

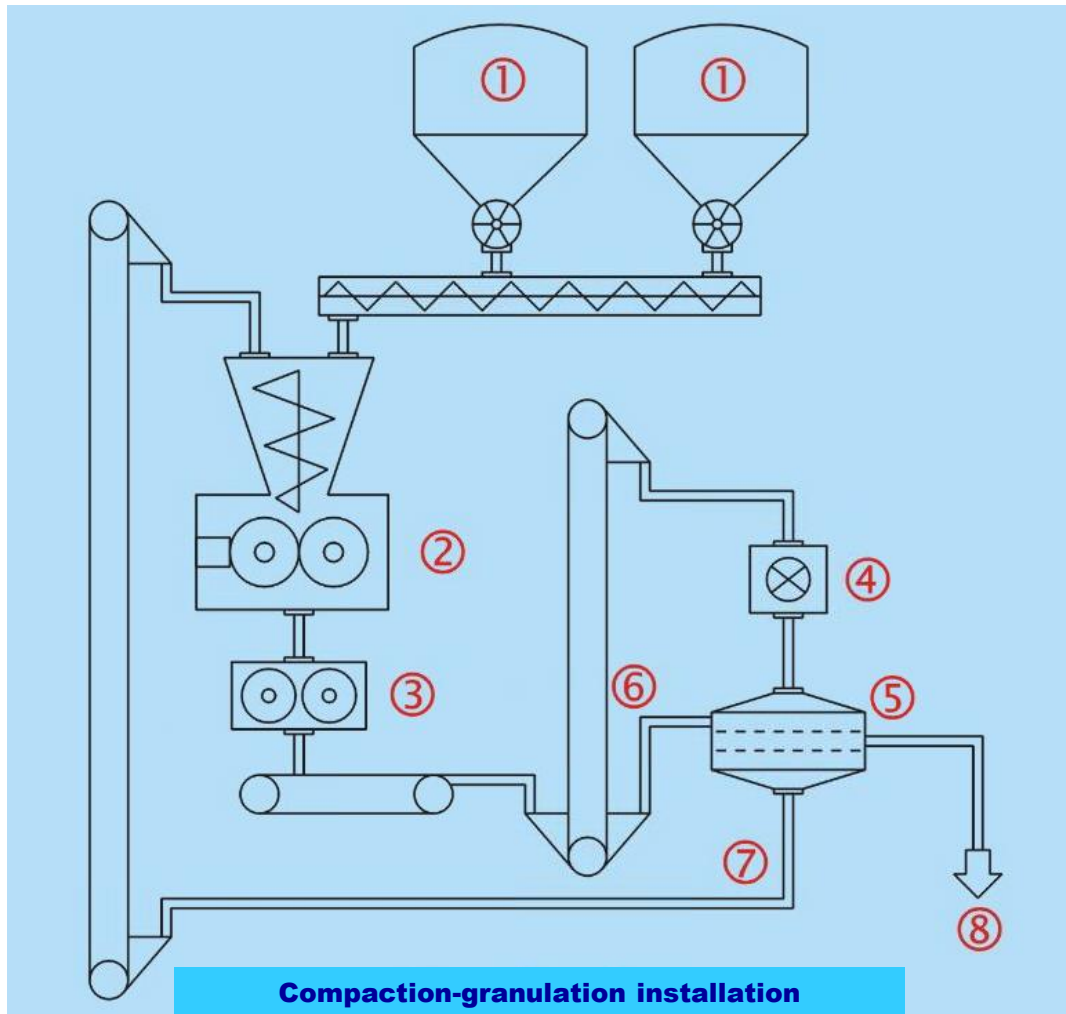

1. Silos, raw materials dosing
2. Compactor
3. Pre-crusher
4. Crusher
5. Sieving machine
6. (Coarse recycling)
7. Fines recycling
8. Final product - Granules



Machines

MS heavy duty series
300 to 1200mm roller diameter

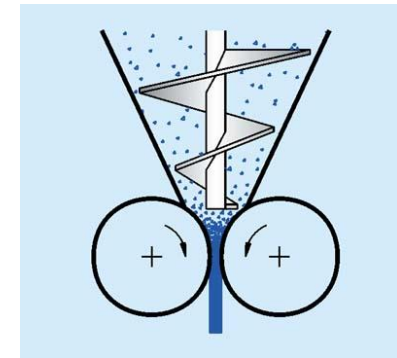
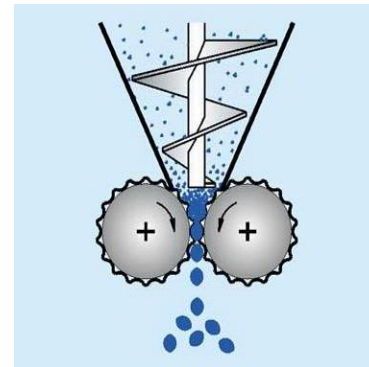

Technical Data

Model	Type	Drive [kW]	Roll Ø [mm]	Press Force [kN]
Alpine Kompaktor®	ARC MS 36	18.5	300	36
Alpine Kompaktor®	ARC MS 60	45	400	60
Alpine Kompaktor®	ARC MS 75	55	520	75
Alpine Kompaktor®	ARC MS 150	132	520	150
Alpine Kompaktor®	ARC MS 300	250	720	300
Alpine Kompaktor®	ARC MS 450	450	800	450
Alpine Kompaktor®	ARC MS 600	800	1000	600
Alpine Kompaktor®	ARC MS 800	1,200	1200	800



HOSOKAWA ALPINE Compaction

A Division of HOSOKAWA ALPINE Aktiengesellschaft

Product examples

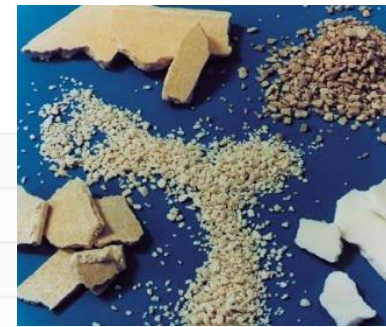

Active carbon/charcoal	Limestone	Sodium nitrate
Adhesives	Maleic anhydride	Sodium Cyanide
Airbag explosives	Melamine	Stabilizers
Alumina / al. (hydr)oxide	MgO	Strontium carbonate
Metal chips	Pesticides	Sugar
Ammonium sulphate	Phenolic resin	Sweetener
Bromium / compounds	Phosphate ore	TCCA
CaO, CaCl ₂	Phytosanitary	Tea Dust
Catalysts	Pigments	Teflon
Detergents	Plant seed	Titaium (alumin.) dioxide
DMT	Plastics	Toner fines
Fertilizer	Potash	Tricalcium phosphate
Flame retardants	K-chloride/Hydroxide/iodide	Uraniumdioxide
Flavours	Rat poison	Valerian
Formaldehyde	Salt NaCl, KCl	Vanadium pentoxide
Frozen food	Precip. Silica	Varnish sludge
Glass batch	Soda ash	Zinc ammonium chloride
Graphite	Sodium benzoate	Pharmaceutical active ingredients
Gypsum	Sodium perborate And many more
Ironoxide	Sodium silicate	



Example

dusty, toxic, corrosive, pyrophoric, radioactive, heat sensitive products

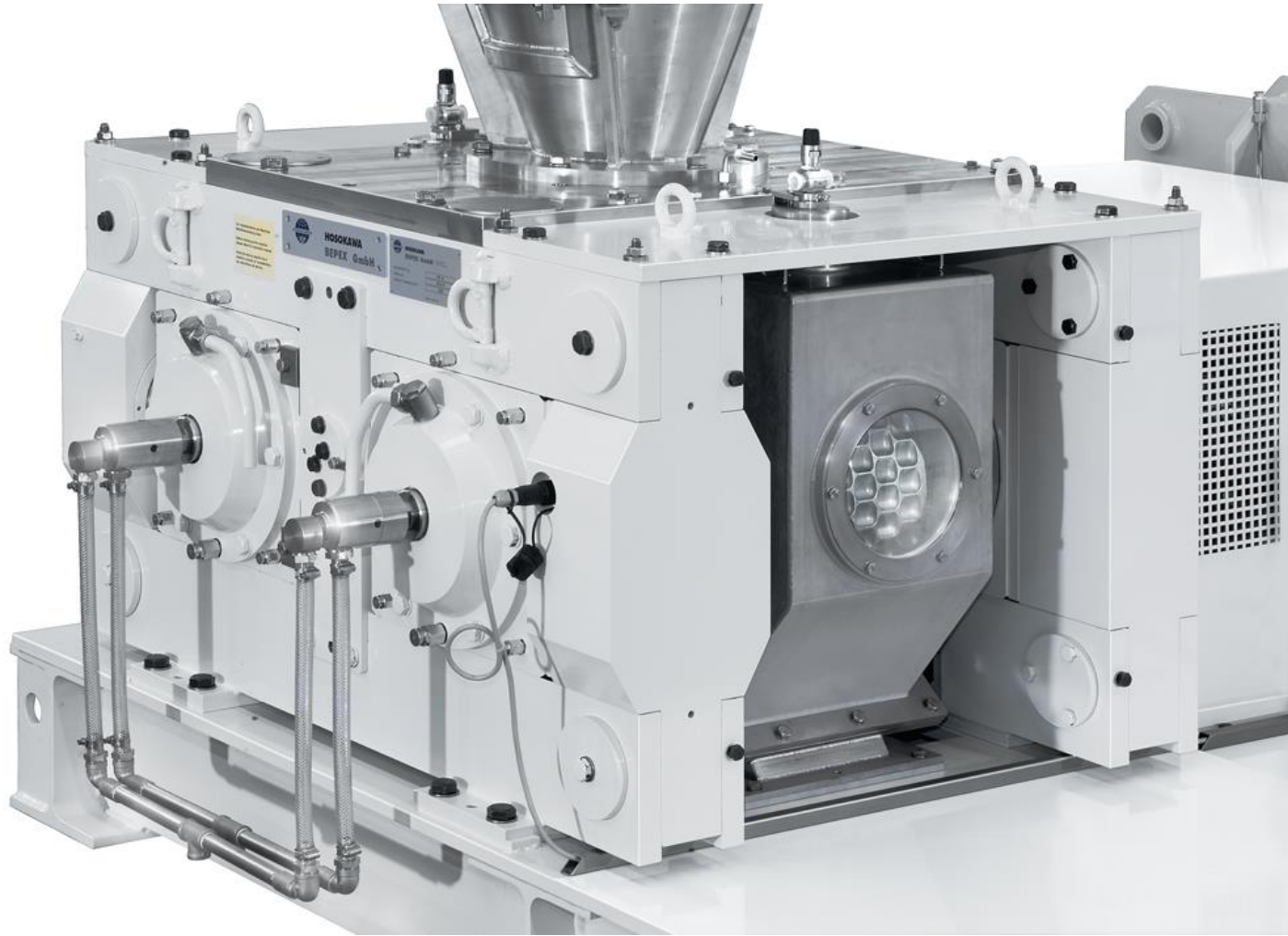

HOSOKAWA ALPINE Compaction
A Division of HOSOKAWA ALPINE Aktiengesellschaft

Example

potent products

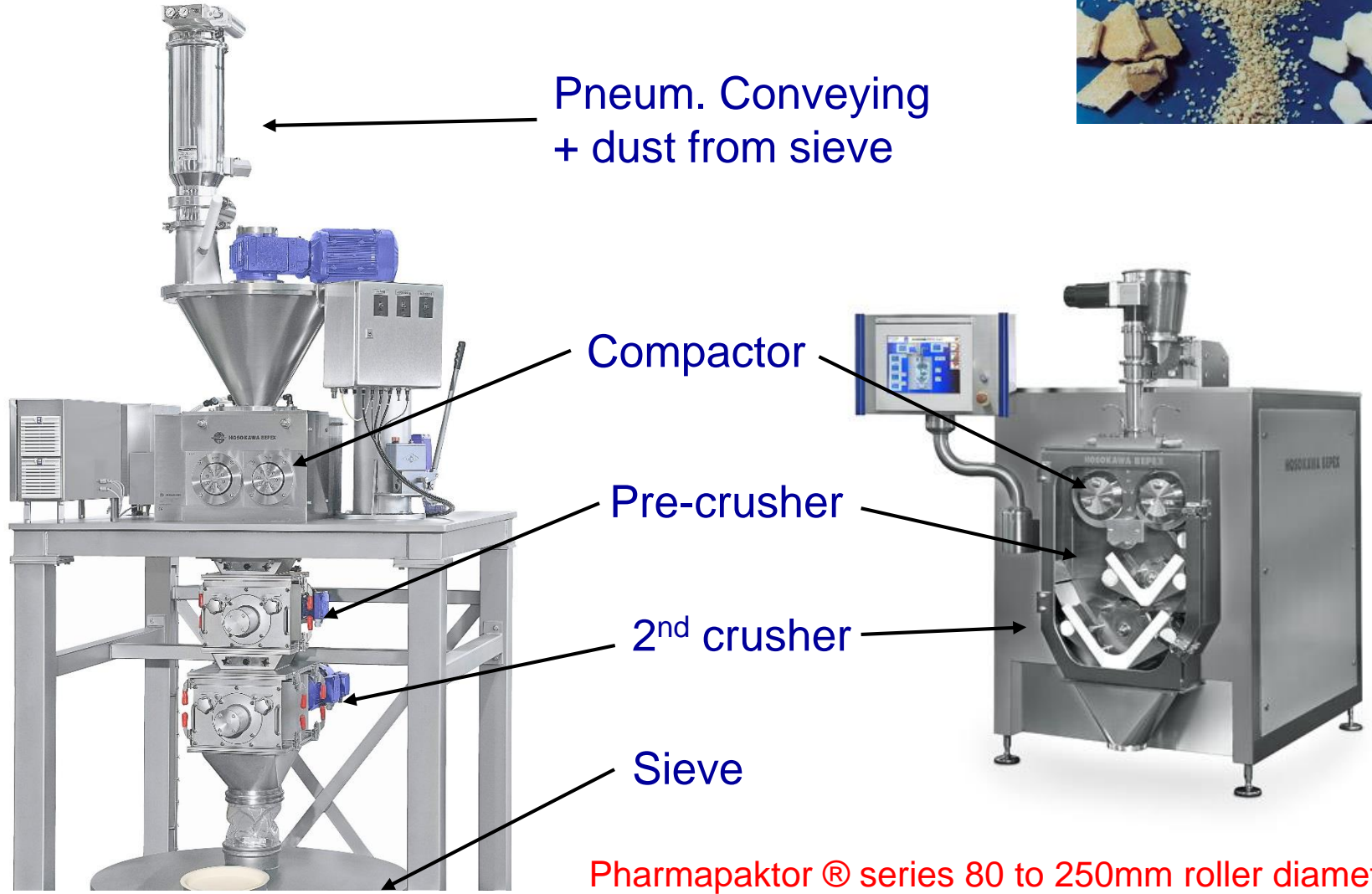

Part 2

Alpine Pelletizing methods

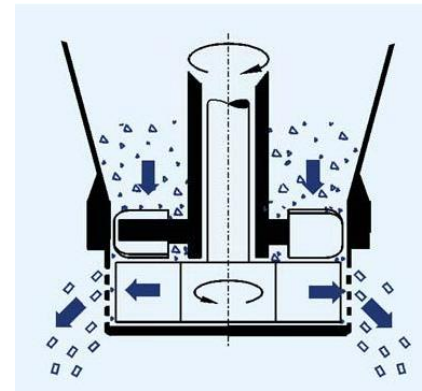
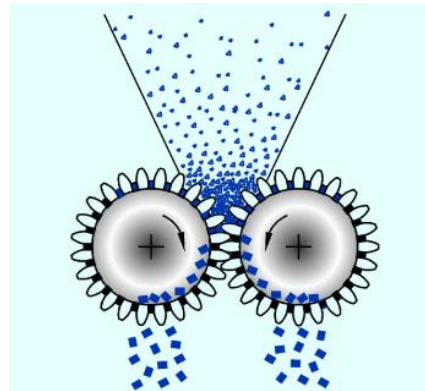

Liquids? Binders? Viscosity?



Medium and Low Pressure Extrusion

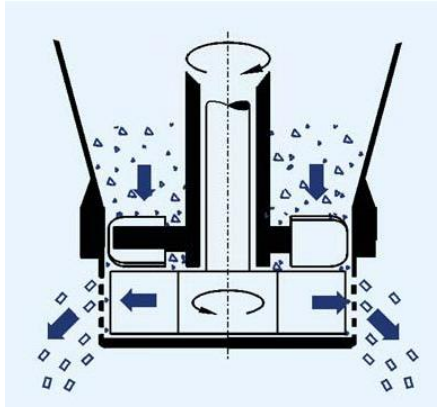

Alpine Bextruder ABX

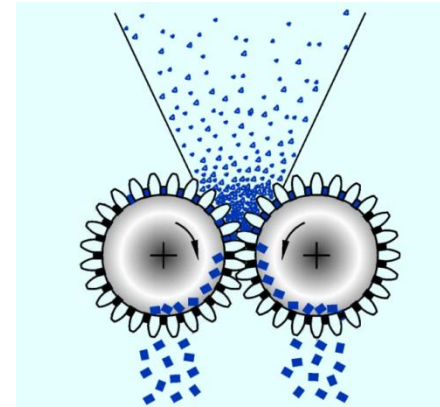

Alpine Gear Pelletizer AGF

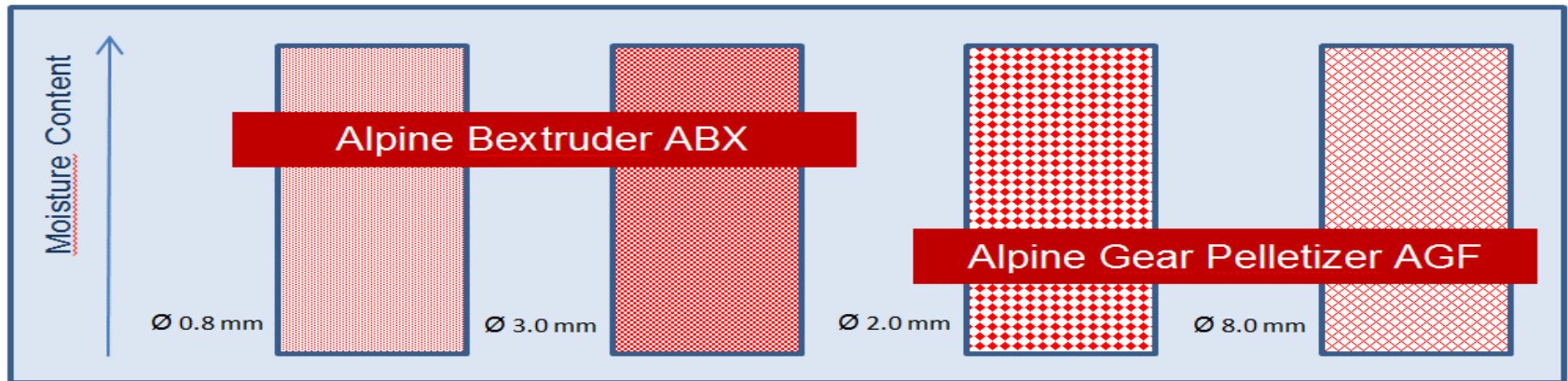

Medium Pressure Extrusion

Alpine Gear Pelletizer AGF

Ø 1 - 8 mm

High pressure

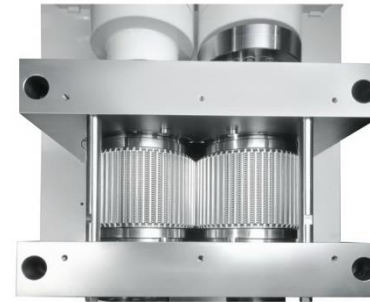
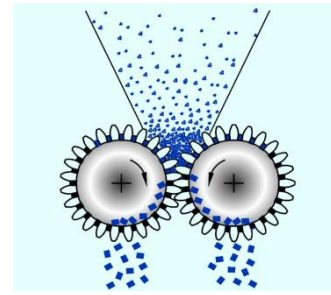

AGF GMS 300

Technical Data

Model	Type	Drive [kW]	Roll Ø [mm]	Width [mm]
Alpine Gear Pelletizer	AGF GCS 200	4.0 - 7.5	200	40 - 100
Alpine Gear Pelletizer	AGF GCS 300	18.5	200	80 - 120
Alpine Gear Pelletizer	AGF GMS 200	11	200	80 - 120
Alpine Gear Pelletizer	AGF GMS 300	22	300	200
Alpine Gear Pelletizer	AGF GMS 300 D	30	300	2 x 200



HOSOKAWA ALPINE Compaction

A Division of HOSOKAWA ALPINE Aktiengesellschaft

Extrusion principle

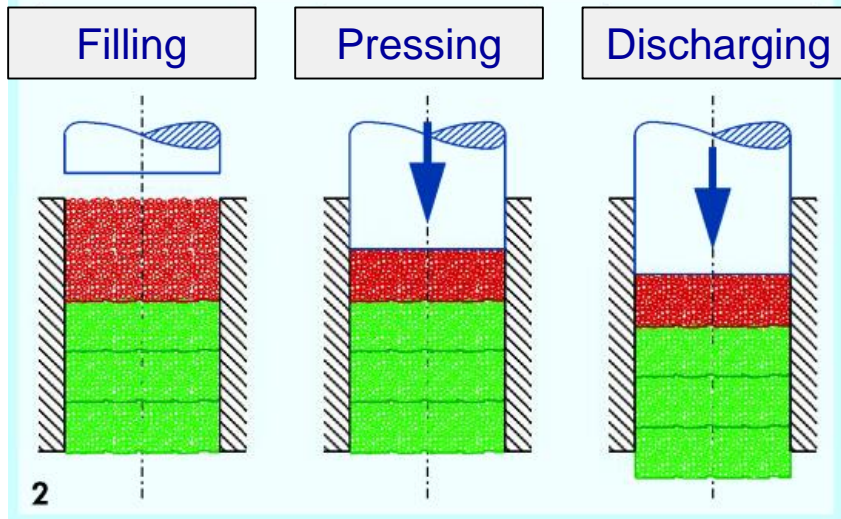
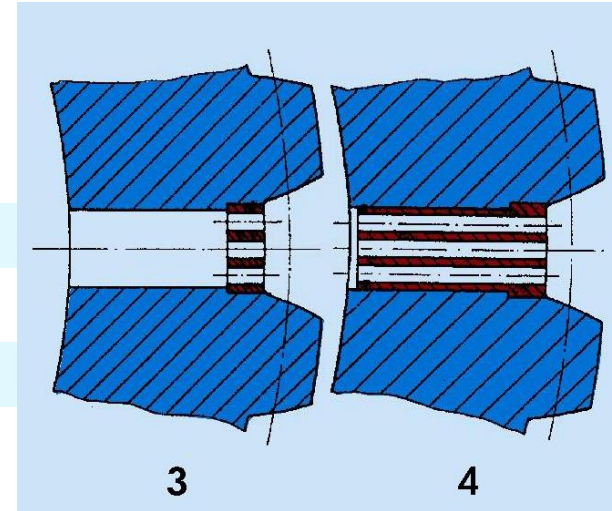
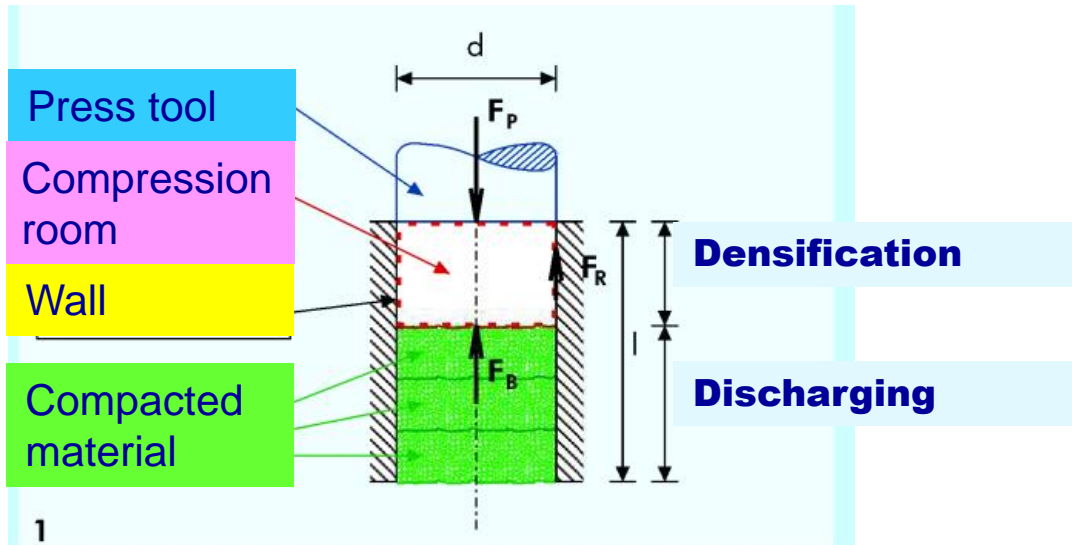

Application

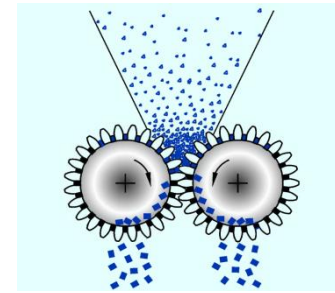

Viscosity is needed!

- Moisture content: < 10 %
- Additives :
 - ▶ Stearate, PVA, PEG
 - ▶ Oil, fat, sugar, maltodextrine
 - ▶ Lignine, starch, molasse

Examples

Stabilisators, CaO with additives, sugar, alternative energy sources, coal based materials, washing detergents, pyrite, filter cake materials, peroxide mixtures, ...



Low Pressure Extrusion

Alpine Bextruder ABX



ABX 450

low pressure

Ø 1- 3 mm

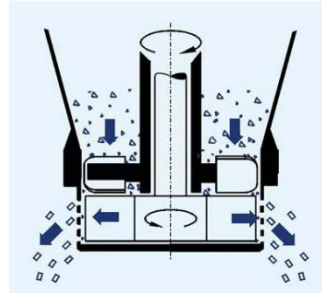

Technical Data

Model	Type	Drive [kW]	Throughput [kg/h]	
			min.	max.
Alpine Bextruder	ABX 150	3	1	300
Alpine Bextruder	ABX 300	8	200	800
Alpine Bextruder	ABX 450	11	400	1,600
Alpine Bextruder	ABX 600	17	800	3,200



HOSOKAWA ALPINE Compaction

A Division of HOSOKAWA ALPINE Aktiengesellschaft

Application

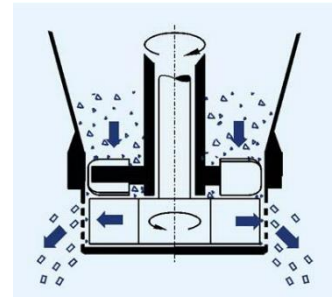

Viscosity is needed!

- Moisture content: 10 – 20 %
- Additives:
 - ▶ Water
 - ▶ Alcohol

Good dissolvability:

Dry soup, Instant tea, Instant coffee, Fish feed, Pesticides, Polymer additives, Dry cleaning agents, ...



Summary

Briquetting, Dry Granulation, Low pressure extrusion

Selection:

Dry process?

Binders required?

Particle size?

Alpine press-agglomeration processes:

- Low energy consumption
- Minimal product heating
- Dust free processing
- Consistent results
- Automatic operation



HOSOKAWA ALPINE Compaction

A Division of HOSOKAWA ALPINE Aktiengesellschaft



**Many thanks
for your attention**



HOSOKAWA ALPINE Compaction
A Division of HOSOKAWA ALPINE Aktiengesellschaft